

NOTICE DE MONTAGE
INSTRUCTIONS FOR ASSEMBLY
MONTAGEANLEITUNG
GEBRUIKSAANWIJZING
ISTRUZIONI DI MONTAGGIO
INSTRUCCIONES DE MONTAJE
INSTRUCOES DE MONTAGEM

buromonic

N° DV40600/03

CONCEPTION ET REALISATION: BUREAU ETUDES BUROMONIC

GARANTIE (warranty)
_ Référence produit à nous communiquer impérativement en cas de litige :
Voir étiquette apposée au dos du produit

GARANTIE (warranty)
_ In the event of complaint, it is essential to mention the product reference :
See label affixed to the back of the product.

GARANTIE (warranty)
_ Im streitfall sit uns die produktreferenz mitzuteilen :
Siehe etikett auf produkdruckseite.

WAARBORG (warranty)
_ Vermeld in geval van klachten altijd het productnummer :
Zie label op de achterzijde van het product

GARANZIA (warranty)
_ Specificare obbligatoriamente il riferimento prodotto in caso di contestazioni :
Si veda l'etichetta applicata dietro il prodotto

GARANTIA (warranty)
_ Referencia de producto citese obligatoriamente en caso de reclamacion :
Ver etiqueta en la parte posterior del producto.

GARANTIA (warranty)
_ Em caso de reclamação indiq-nos imperativamente a referência do produto :
Ver etiqueta fixada na parte posterior do produto

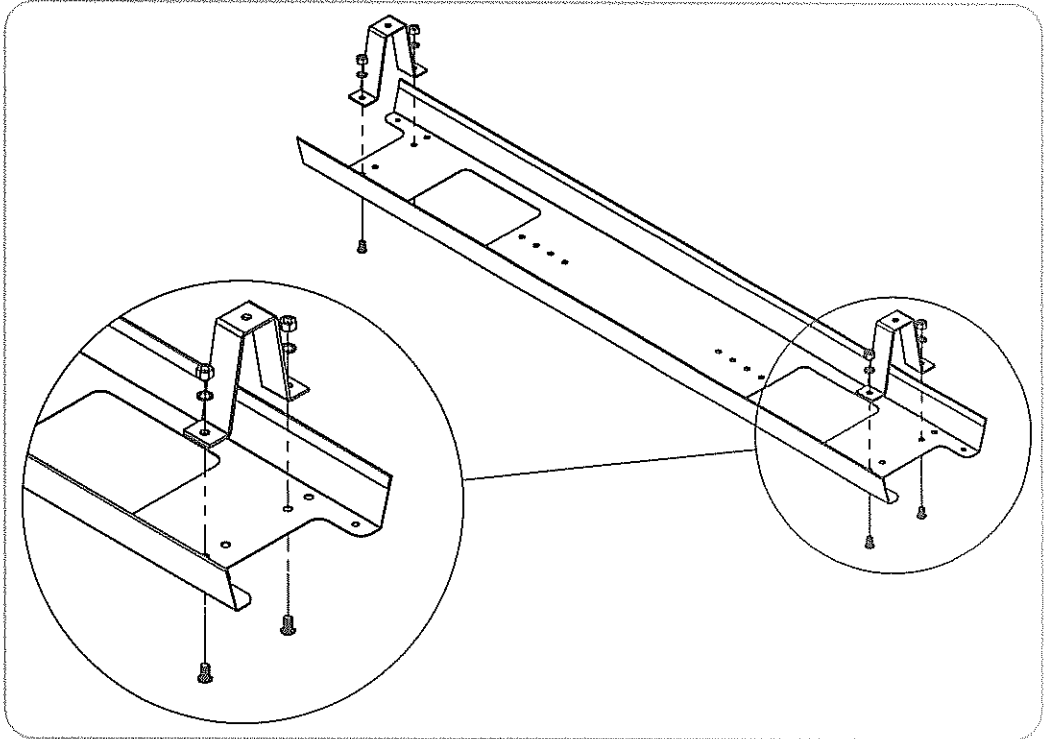
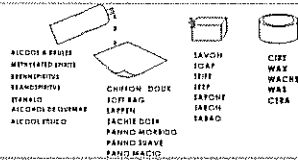
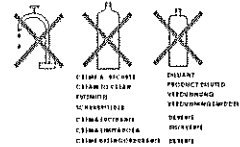
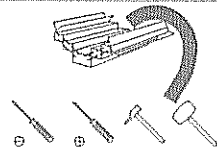
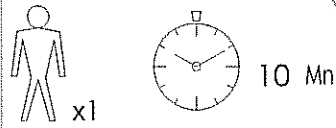
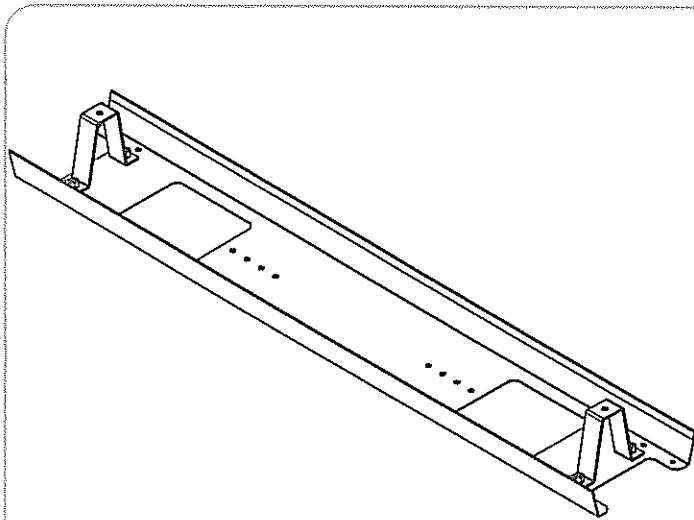

NOMENCLATURE (Parts list)
(Stückliste)
(Onderdelenlijst)
(Nomenclatura)
(Lista de peças)

QUINCAILLERIE (Hardware)
(Beschläge)
(Izzerwaren)
(Ferramentas)
(Quinquilharia)

Rep.	Pièce	Qtè	A	B	C
A	GOULOTTE	1			
B	SUSPENTE	2			
C	VIS TBHc M6x12	4			
D	Rondelle éventail	4			
E	Ecrrou M6	4			
F	VIS TCHC M6x16	2			
G	Clé 6 pans 4mm	1			
H	Vis TR 5 x20	2			
M					
N					
O					
P					
Q					
R					

AIDE

HELP
HILFE
HULP
AYUDA
AJUDA
AIUTO

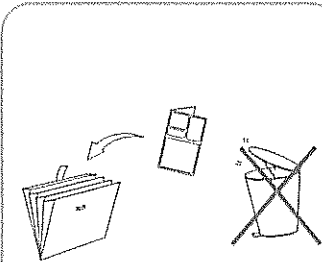
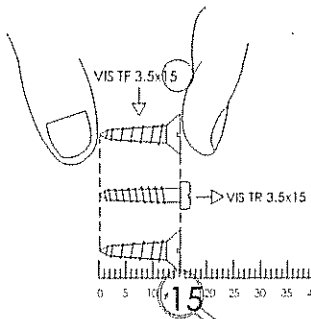

1

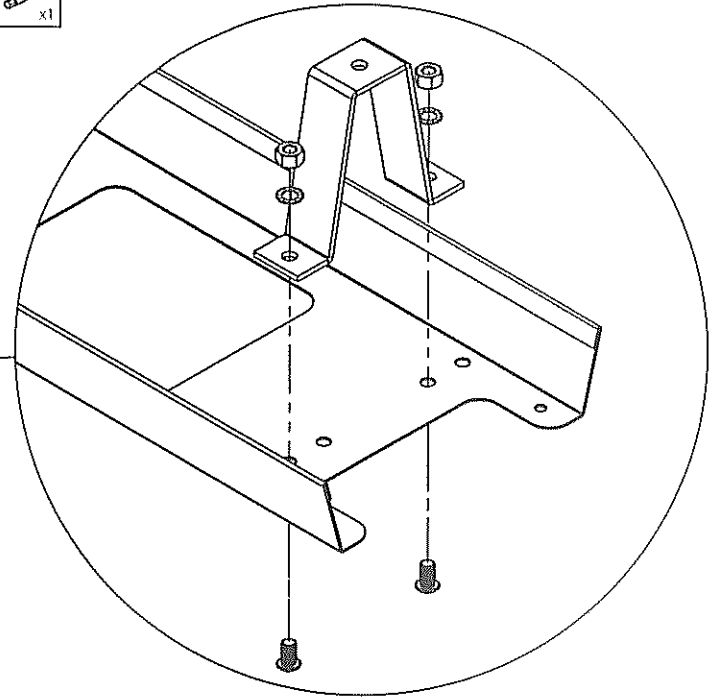
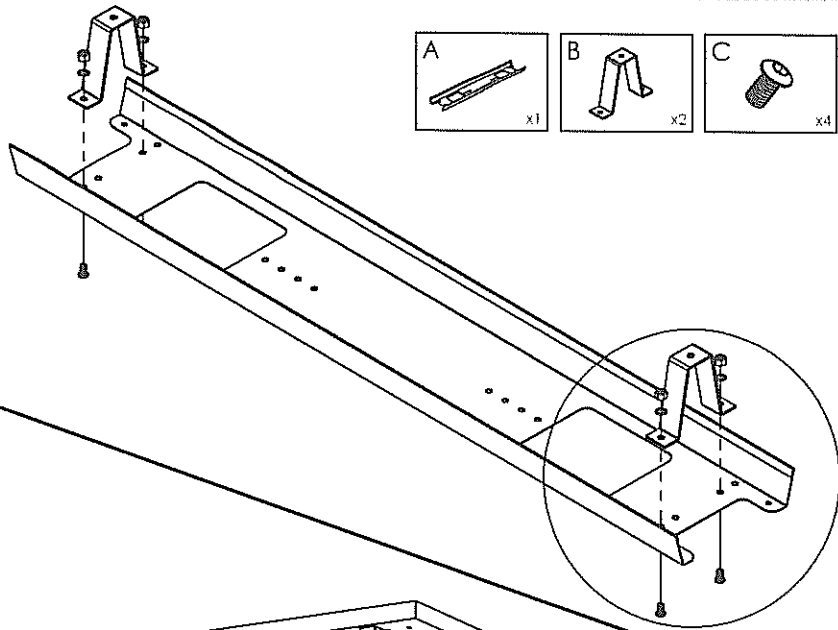
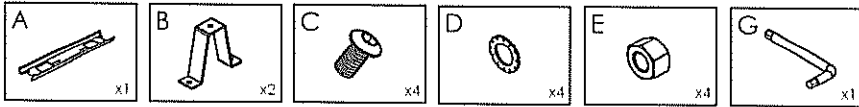

2

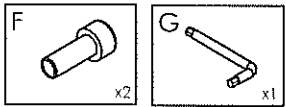
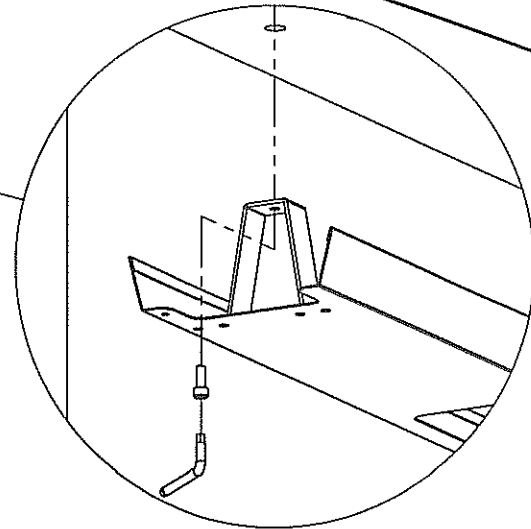
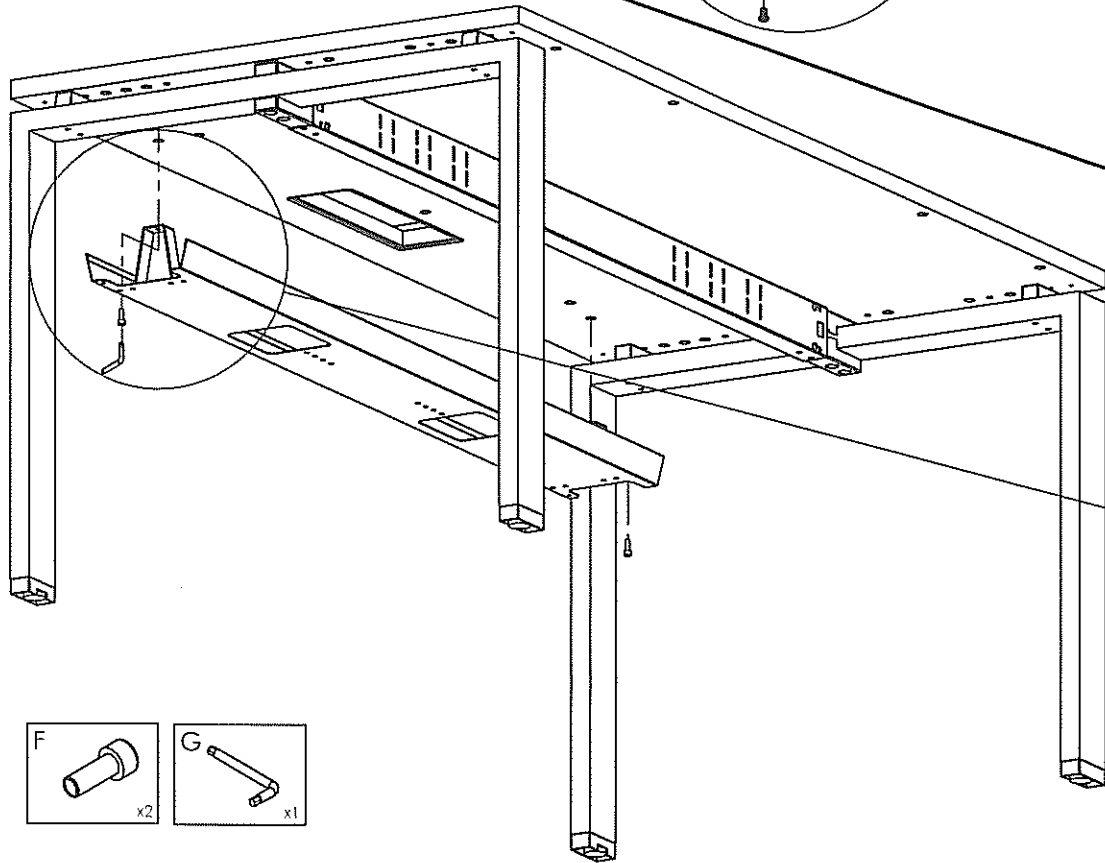

NOTICE DE MONTAGE
INSTRUCTIONS FOR ASSEMBLY
MONTAGEANLEITUNG
GEBRUIKSAANWIJZING
ISTRUZIONI DI MONTAGGIO
INSTRUCCIONES DE MONTAJE
INSTRUCOES DE MONTAGEM

buronomic

N° DV40705

CONCEPTION ET REALISATION BUREAU D'ETUDES BURONOMIC

GARANTEE (vissas cachets)

_ Réference produit à nous communiquer impérativement en cas de litige :
Voir étiquette apposée au dos du produit

GARANTEE (sticker)

_ In the event of complaint, it is essential to mention the product reference :
See label affixed to the back of the product.

GARANTEE (sticker)

_ Im streitfall sit uns die produktreferenz mitzuteilen :
Siehe etikett auf produktrückseite.

WAARBORG (do verborgen getrokken)

_ Vermeld in geval van klachten altijd het productnummer :
Zie label op de achterzijde van het product

GARANZIA (vissacachetti)

_ Specificare obbligatoriamente il riferimento prodotto in caso di contestazioni :
Si veda l'etichetta applicata dietro il prodotto

GARANZIA (sticker)

_ Referencia de producto citese obligatoriamente en caso de reclamacion :
Ver etiqueta en la parte posterior del producto.

GARANZIA (vissas cachetas)

_ Em caso de reclamação indiqu-nos imperativamente a referência do produto :
Ver etiqueta fixada na parte posterior do produto

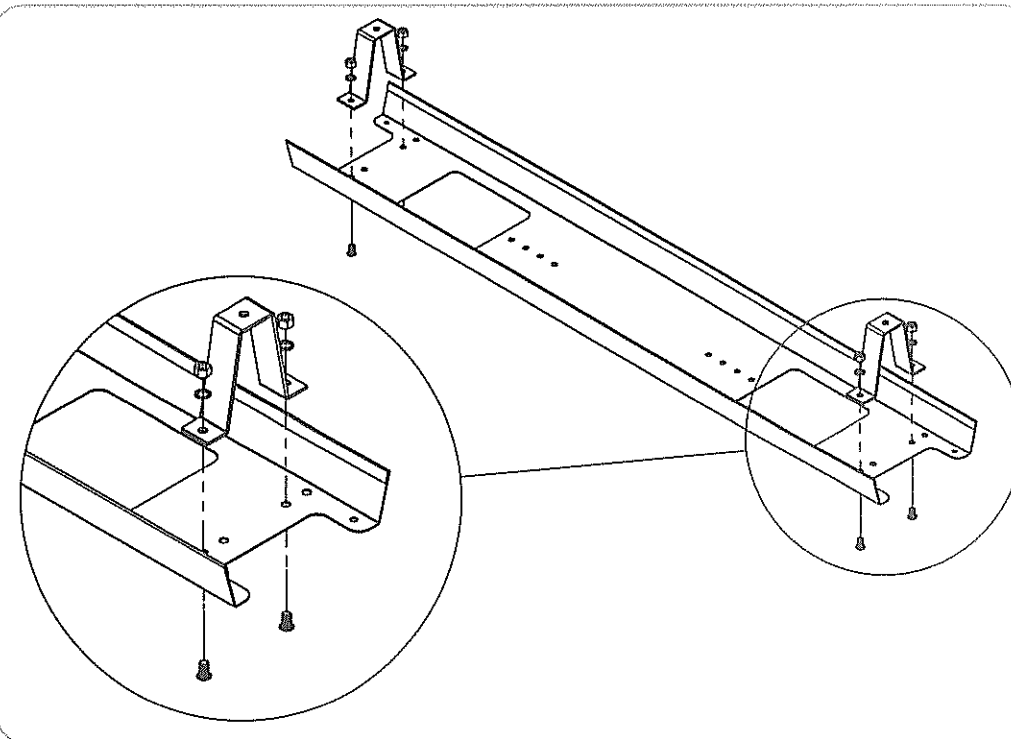
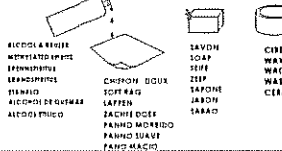
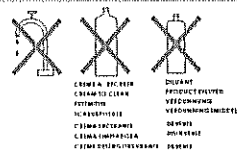
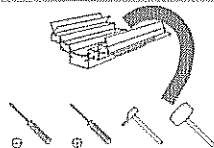
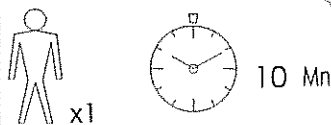
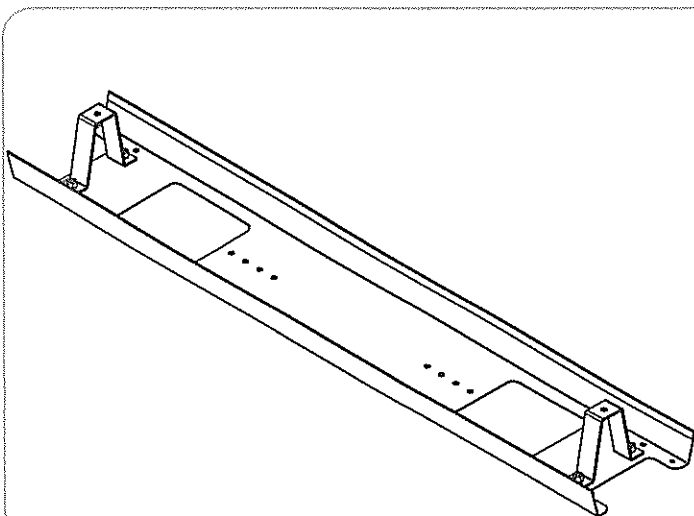

NOMENCLATURE

(Parts list)
(Stückliste)
(Onderdelenlijst)
(Nomenclatura)
(Lista de peças)

QUINCAILLERIE

(Hardware)
(Beschläge)
(Ijzerwaren)
(Ferramenta)
(Herrajes)
(Quinquilharia)

Rep.	Pièce	Qtè	A	B	C
A	GOULOTTE	1			
B	SUSPENTE	2			
C	VIS TBHc M6x12	4			
D	Rondelle éventail	4			
E	Ecrou M6	4			
F	VIS TCHC-M6x16	2			
G	Clé 6 pans 4mm	1			
H	Vis TR 5 x20	2			
J					
K					
L					
M					
N					
O					
P					
Q					
R					

AIDE

HELP
HILFE
HULP
AYUDA
AJUDA
AIUTO

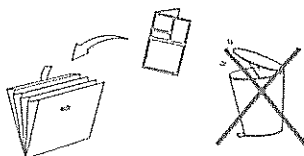
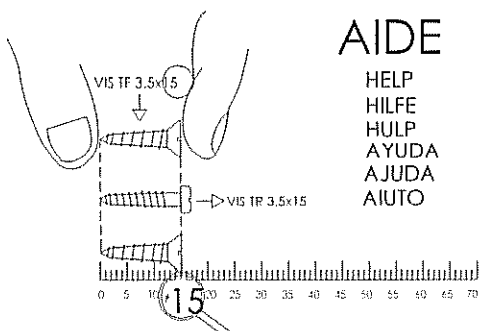

1

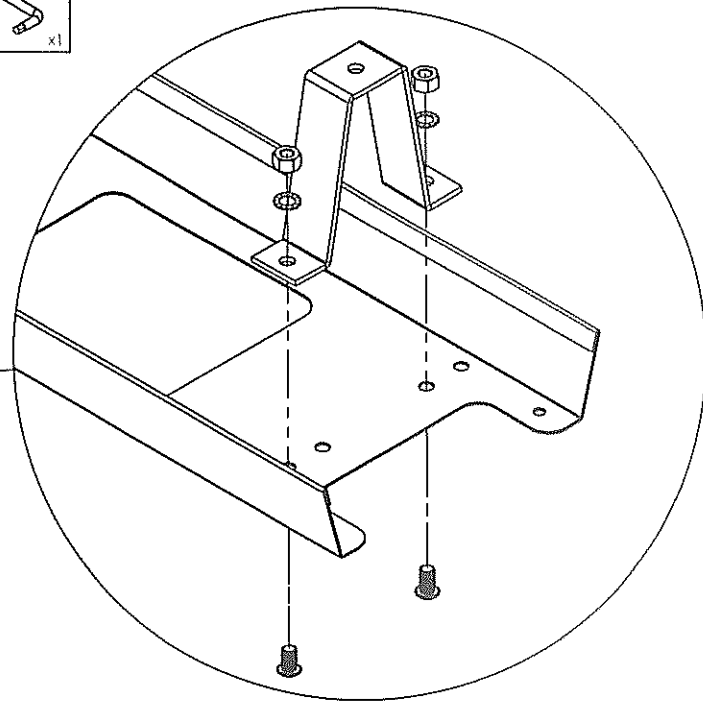
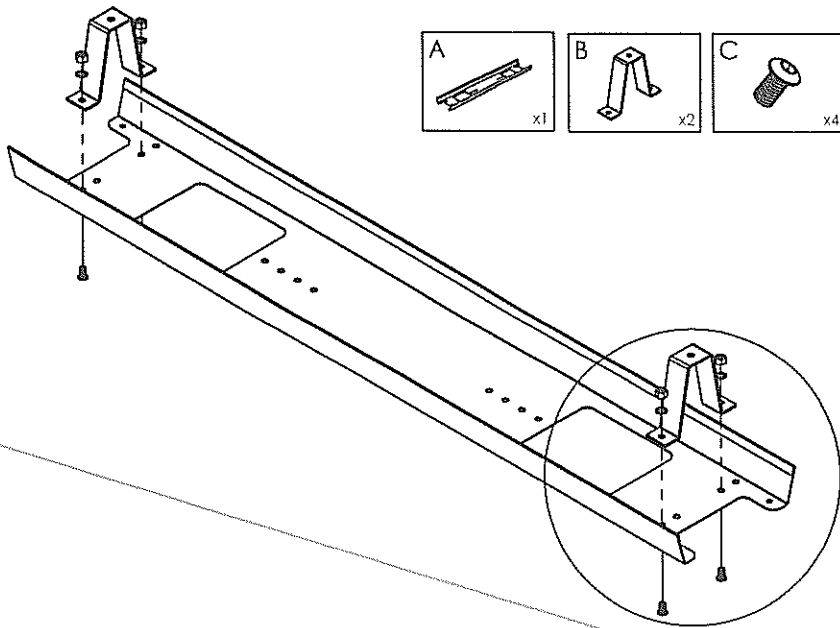
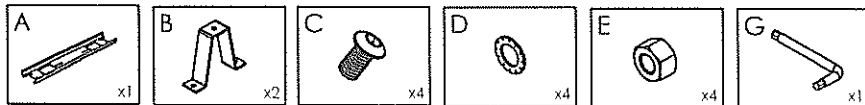

2

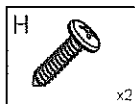
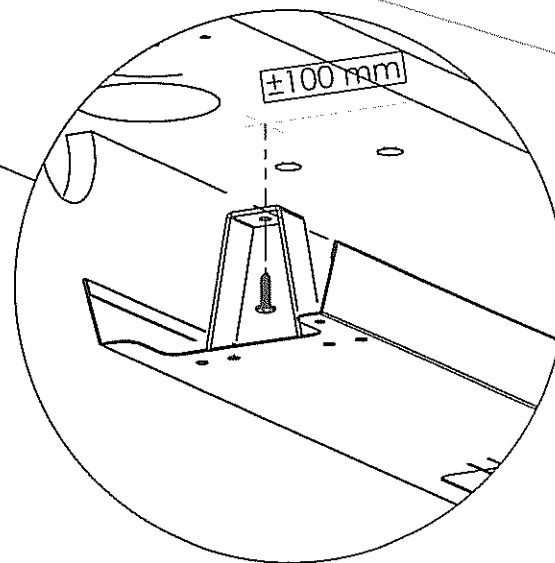
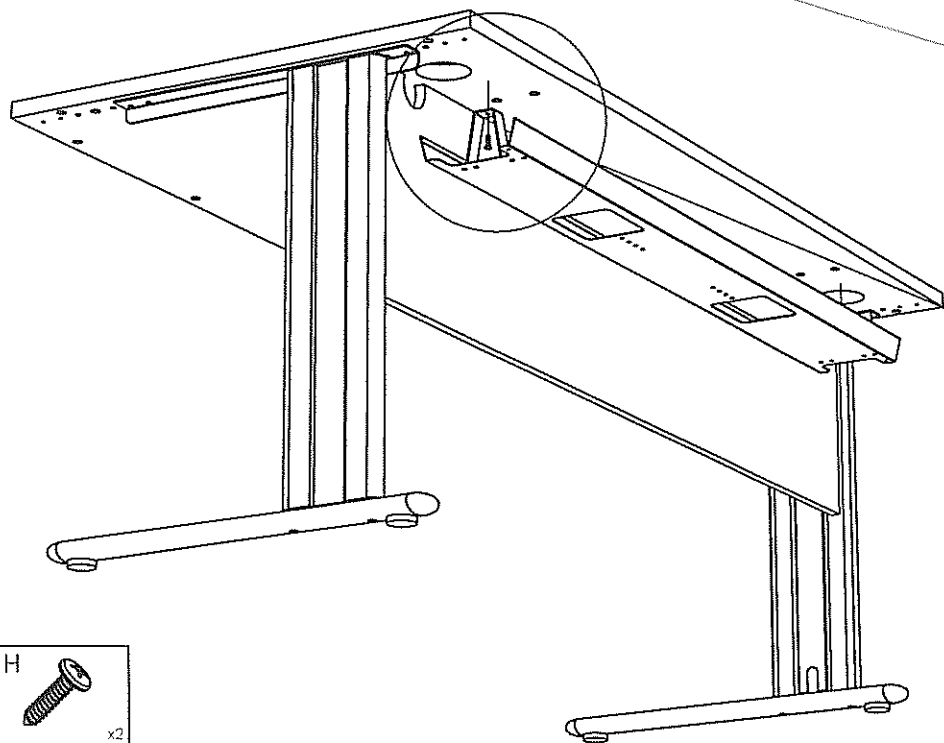

NOTICE DE MONTAGE
INSTRUCTIONS FOR ASSEMBLY
MONTAGEANLEITUNG
GEBRUIKSAANWIJZING
ISTRUZIONI DI MONTAGGIO
INSTRUCCIONES DE MONTAJE
INSTRUCCOES DE MONTAGEM

buronomic

N° DV40566/01

CONCEPTION ET REALISATION BUREAU D'ETUDES BURONOMIC

GARANTIE (warranty)
_ Référence produit à nous communiquer impérativement en cas de litige :
Voir étiquette apposée au dos du produit

GARANTEE (warranty)
_ In the event of complaint, it is essential to mention the product reference :
See label affixed to the back of the product.

GARANTIE (warranty)
_ Im streitfall sit uns die produktreferenz mitzuteilen :
Siehe etikett auf produkttruckseite.

WAARBORG (warranty)
_ Vermeld in geval van klachten altijd het productnummer :
Zie label op de achterzijde van het product

GARANZIA (warranty)
_ Specificare obbligatoriamente il riferimento prodotto in caso di contestazioni :
Si veda l'etichetta applicata dietro il prodotto

GARANTIA (warranty)
_ Referencia de producto citese obligatoriamente en caso de reclamacion :
Ver etiqueta en la parte posterior del producto.

GARANTIA (warranty)
_ Em caso de reclamacao indiqu-nos imperativamente a referencia do produto :
Ver etiqueta fixada na parte posterior do produto

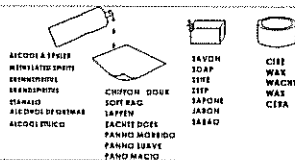
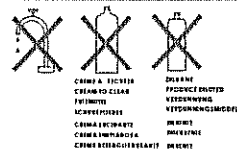
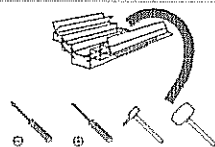
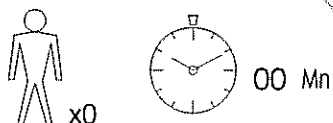
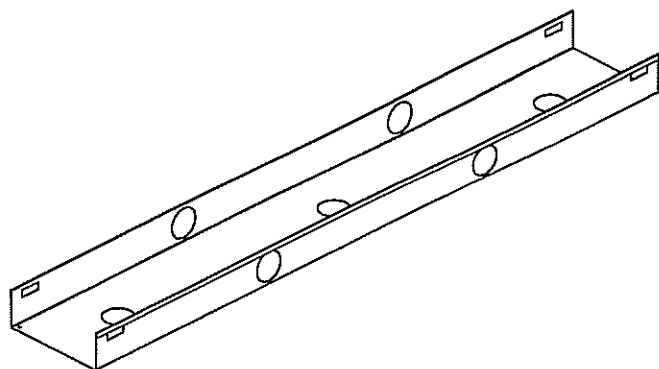
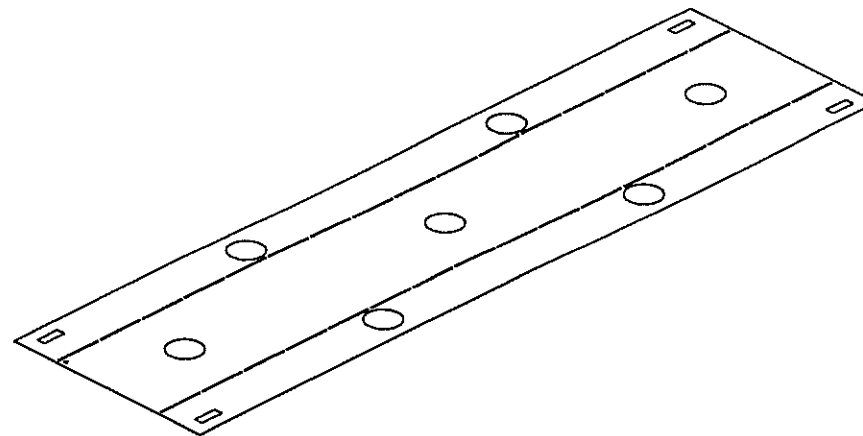

NOMENCLATURE
(Parts list)
(Stückliste)
(Onderdelenlijst)
(Nomenclatura)
(Lista de peças)

QUINCAILLERIE
(Hardware)
(Beschläge)
(Jzerwaren)
(Ferramentas)
(Herrajes)
(Quinquilharia)

A	B	C
D	E	F
G	H	I
J	K	L
M	N	O
P	Q	R

AIDE

HELP
HILFE
HULP
AYUDA
AJUDA
AIUTO

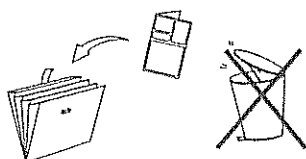
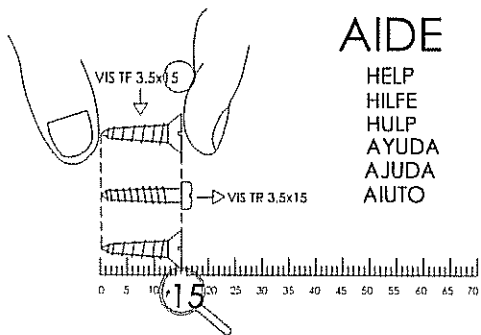

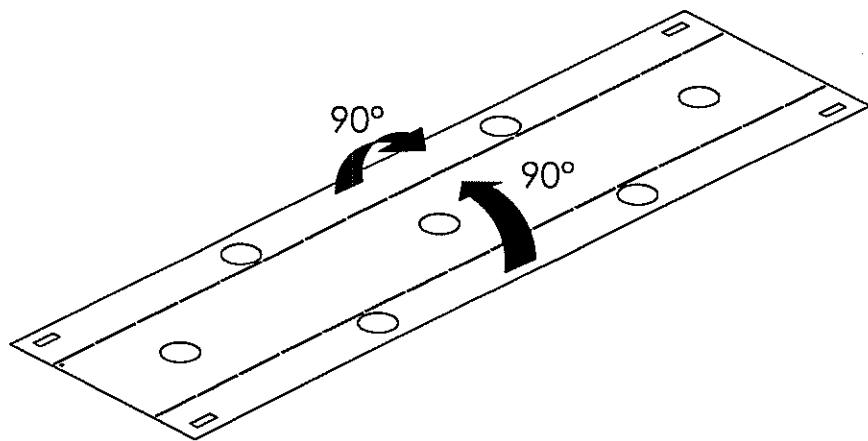
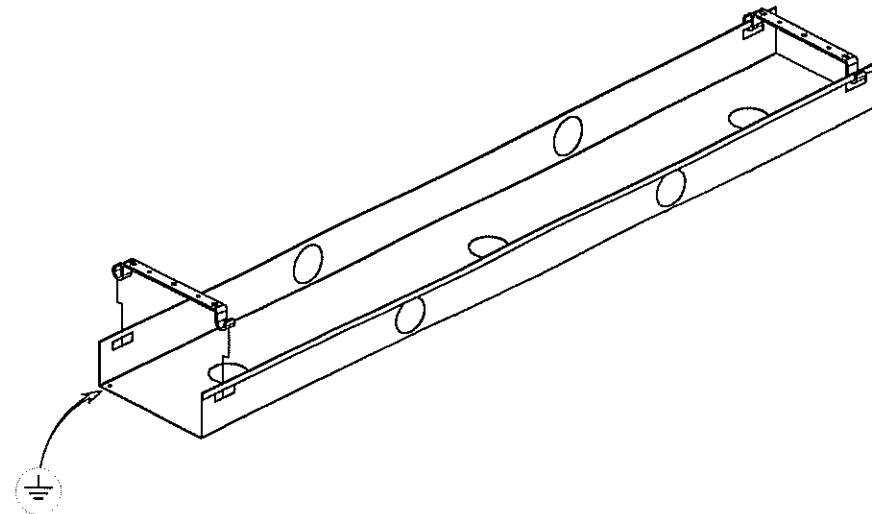
1**2a****2b**

Rep.	Pièce	Qté
A	GOULOTTE Tôle pliée 8/10 - PLAN 120	1
B	CROCHET GOULOTTE SUSPENDUE	4
C	VIS TCHC M6x16	4
D	Clé 6 pans 5mm	1

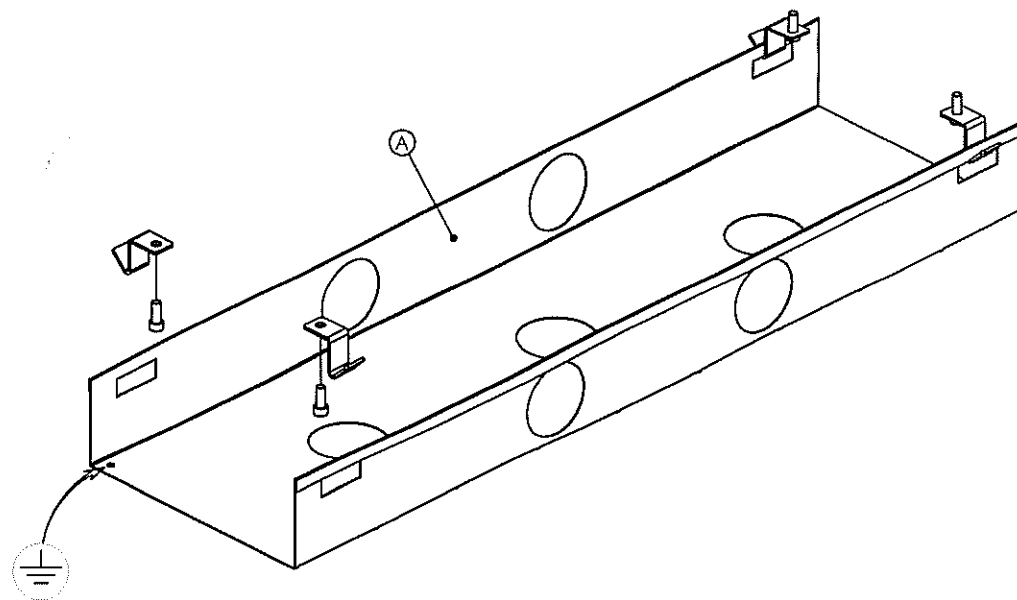
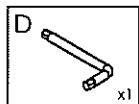
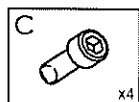
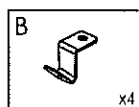
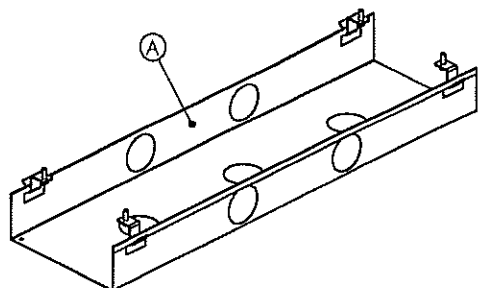

NOTICE DE MONTAGE

INSTRUCTIONS FOR ASSEMBLY
MONTAGEANLEITUNG
GEBRUIKSAANWIJZING

buronomic.

N° 40458/00
LE : 29.03.05

CONCEPTION ET REALISATION BUREAU D'ETUDES BURONOMIC

GARANTIE (des vices cachés)

GARANTEE (defekt)
GARANTIE (fabrikationsfehler)
WAARBORG (de verborgen gebreken)

INFORMATION à nous communiquer impérativement en cas de litige.
Please give us this information if there is a mistake.
Geben Sie uns diese Auskunft für einen Rechtsstreit.
DEZE INLICHTINGEN MOETEN ONS GEDEELD WEE GEDEELD WORDEN PLE TWISTGESPREK

**SE REFERER A L'ETIQUETTE APOSEE
AU DOS DU PRODUIT**

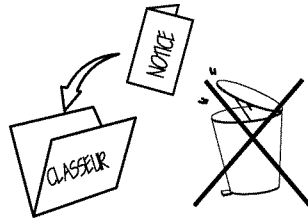
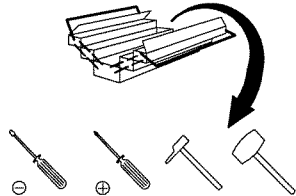
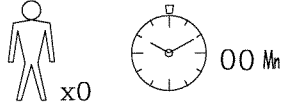
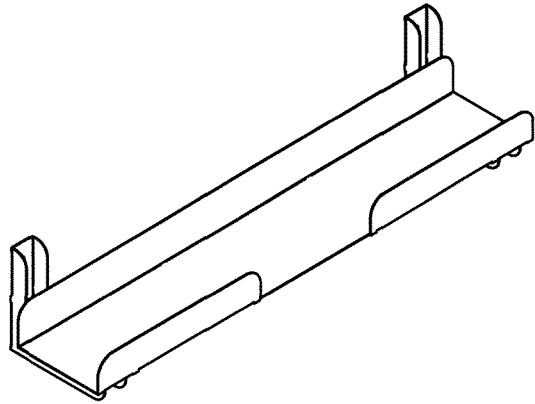
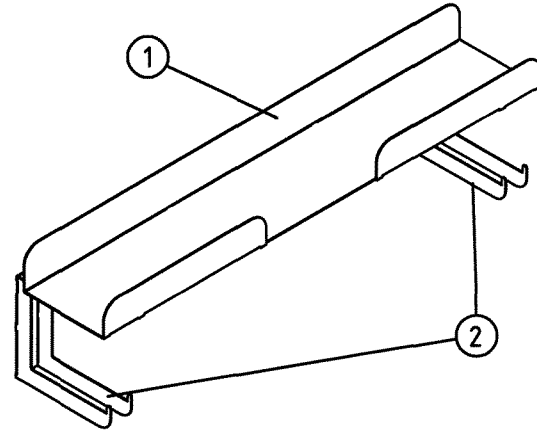

NOMENCLATURE (LIST OF PARTS) (NOMENCLATURE) (TERMINOLOGIE)

Rep	Nbre	Designation de la pièce
1	1	Goulotte métallique
2	2	Equerre métallique
3		
4		
5		
6		
7		
8		
9		
10		
11		
12		
13		
14		
15		
16		
17		
18		
19		
20		
21		
22		
23		
24		
25		
26		
27		
28		
29		
30		
31		
32		
33		
34		
35		
36		
37		
38		

QUINCAILLERIE (HARDWARE) (EISENWAREN) (LIJZERWAREN)

A	B	C	D	E
VIS 4x15 x4	x0	x0	x0	x0
F	G	H	I	J
x0	x0	x0	x0	x0
K	L	M	N	O
x0	x0	x0	x0	x0

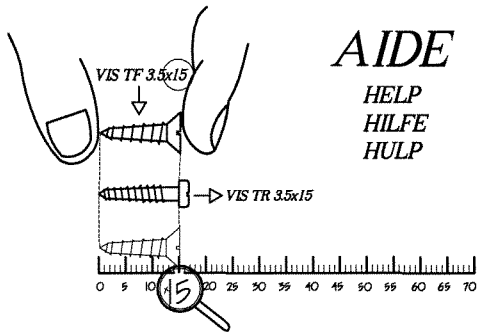

AIDE
HELP
HILFE
HULP

ENTRETIEN (CLEANING) UNTERHALTUNG GESPREK



CHIFFON A SECOUR
CREME TO CLEAN
PUTZMITTEL
SOAPPONPOEDEL

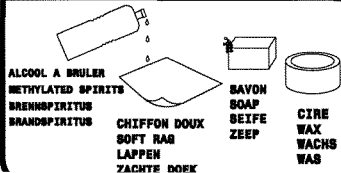

ALCOOL A BRULER
METHYLATED SPIRITS
BRENNSPIRITUS
BRANDSPIRITUS

CHIFFON DOUX
SOFT RAG
LAPPEN
Zachte Doek

BAYON SOAP
BEIFE
ZEEP

CIRE
WAX
WACHS
WAS

